

# FlowSonic<sup>®</sup>

by sentronics<sup>®</sup>

The FlowSonic<sup>®</sup> LF ultrasonic sensor from Sentronics<sup>™</sup> represents a breakthrough in fuel flow measurement technology for automotive engines of every type. The FlowSonic LF has been designed for the ultra low-volume fuel flow conditions found in today's high-efficiency road car engines, making it an ideal tool for R&D as well as emissions testing to the new RDE and WLTP standards. Key features and advantages include:

- ✔ Compact, lightweight, no moving parts
- ✔ Easily installed on test bench or vehicle
- ✔ Highly accurate and repeatable
- ✔ Extremely robust and vibration-tolerant
- ✔ -40°C to +120°C temperature range
- ✔ Internal processing and diagnostics
- ✔ Fast measurement rate for dynamic flows
- ✔ CAN, TTL pulse, analog output formats
- ✔ Class-leading ultrasonic turndown ratio
- ✔ Minimal operating and maintenance cost

## FlowSonic<sup>®</sup> LF Dimensions (mm)

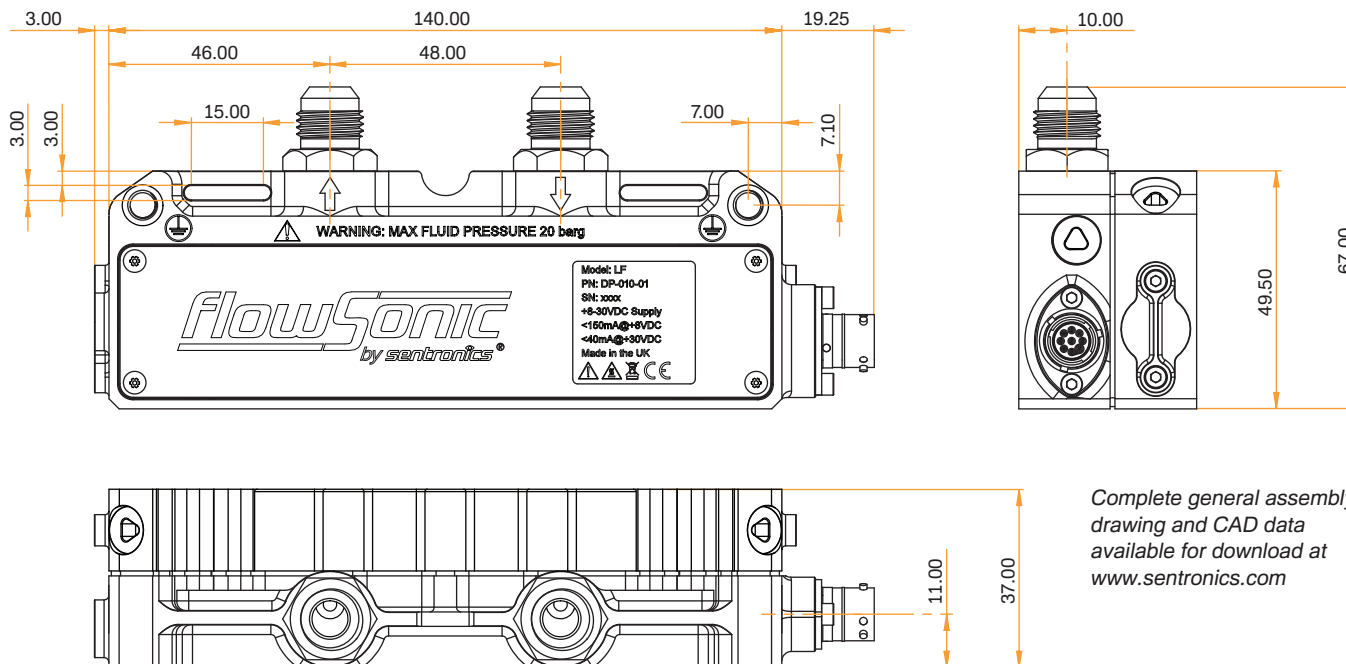

# FlowSonic<sup>®</sup> LF Low-Flow Sensor

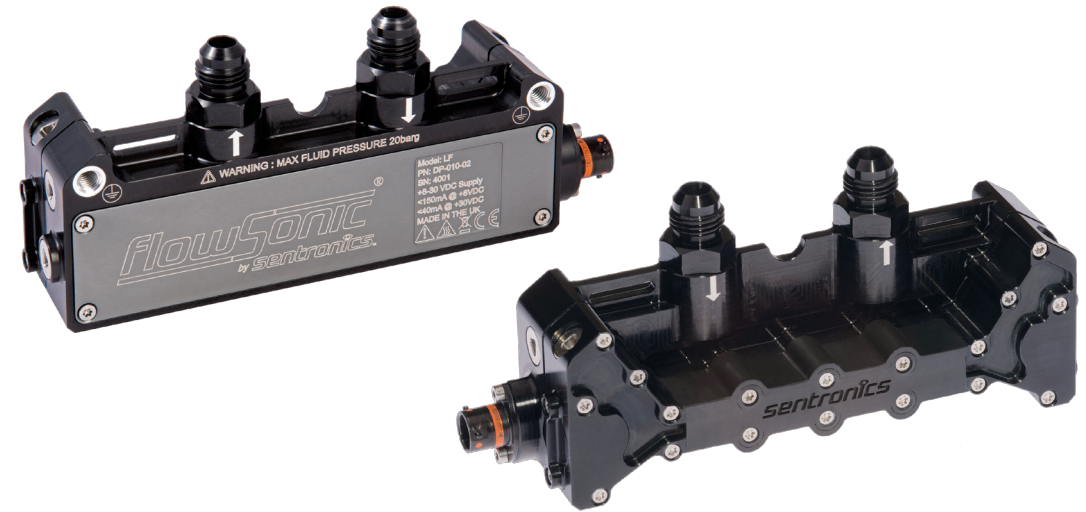

## FlowSonic<sup>®</sup> LF Pin Out Functions

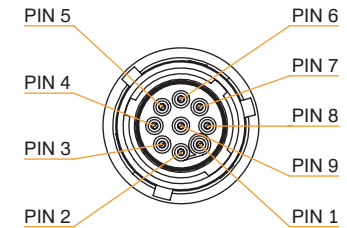

### Deutsch ASDD006-09PC-HE Sensor Connector

Pin 1	Supply +
Pin 2	CAN High
Pin 3	CAN Low
Pin 4	TTL Pulse Output
Pin 5	Analog Output
Pin 6	Comms A
Pin 7	Comms B
Pin 8	CAN Select
Pin 9	Ground (GND)

Complete general assembly drawing and CAD data available for download at [www.sentronics.com](http://www.sentronics.com)

## FlowSonic® LF Specifications and Features DP-010-02

### Flow Measurement

Repeatability	+/- 0.15% of reading
Uncertainty*	+/- 0.5% of reading
Turndown ratio	500:1
Operating flow range	+/- 0-4000 ml/min
Measurement flow range	8-4000 ml/min
Measurement rate	2.2 kHz
Maximum operating pressure	20 barg (2000 kPag)
Pressure drop at maximum flow	< 20 kPa (4000 ml/min for pump petrol @ 20°C)
Fluid temperature range	-20°C to +120°C
Ambient temperature range	-40°C to +120°C
<b>Temperature Measurement</b>	2 x 1000 Ohm RTD (1/3 DIN standard)

### Mechanical

Dry weight	330 g
Fluid capacity	15 ml
Wetted materials	FPM, anodised aluminium alloy, stainless steel
Fuel line connection	-6AN fittings 9/16-inch UNF thread
Deutsch sensor connector	ASDD006-09PC-HE
Deutsch mating connector	ASDD606-09SC-HE

### Environmental

Storage temperature	-40°C to 85°C
External pressure rating	300 kPa
Environmental protection	IP69K (when mated to connector)

\* Calculated according to ISO/TR using root-sum square method yielding 95% confidence

### Electrical Supply

Voltage	8V to 30V DC
Current	< 70 mA @ +12V DC
Voltage protection	Over-voltage 45V DC, reverse polarity -45V DC

### CAN Communications

Design standard	ISO 11898-2 (high-speed applications)
Message format	2.0A (11-bit identifier)
Baud rate	1 Mbit/sec
CAN termination resistor	No

### TTL Pulse Output

Voltage output range	0-5V
Pulses per cc	3000 (fully configurable)
Duty cycle	50%
Output resistance	1.0 kOhm

### Analog Output

Voltage output range	0-10V DC
Resolution	16-bit
Output resistance	47.0 Ohm
Load resistance	> 1.0 kOhm

### Configuration Interface

3.3V serial interface

### Fuel Compatibility

Petrol, diesel, bio-diesel, ethanol, methanol  
*please contact us about other fluids*

*Specifications subject to change without prior notice*