

FlowSonic

BY *sentronics*™

The FlowSonic® range of ultrasonic fuel flow sensors from Sentronics™ is designed for both performance (optimising fuel use and strategy) and regulatory (balancing performance and limiting peak engine power) applications in motorsport. Key features and benefits include:

- ✓ Compact, lightweight, no moving parts
- ✓ Highly accurate and repeatable
- ✓ -20 to +120°C temperature range
- ✓ Internal processing and diagnostics
- ✓ Fast measurement rate for dynamic flows
- ✓ Extremely robust and vibration-tolerant
- ✓ Compatible with wide range of fuel types
- ✓ Minimal operating and maintenance cost

Motorsport Fuel Flow Sensor Series



● ● FIA Formula 1 World Championship® ● IMSA®/ FIA World Endurance Championship®

Dimensions (mm)

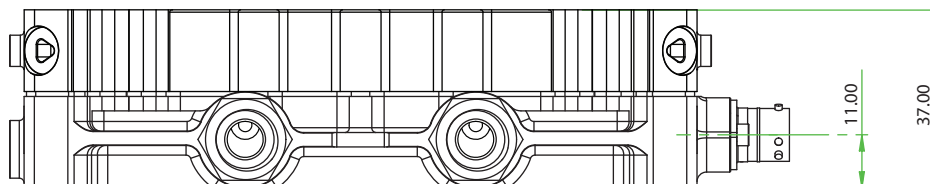
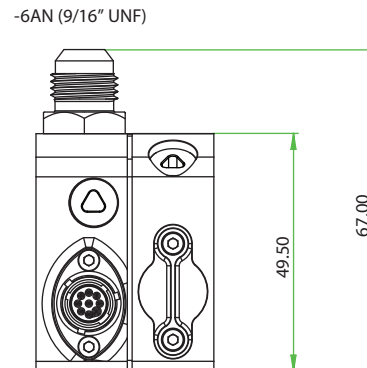
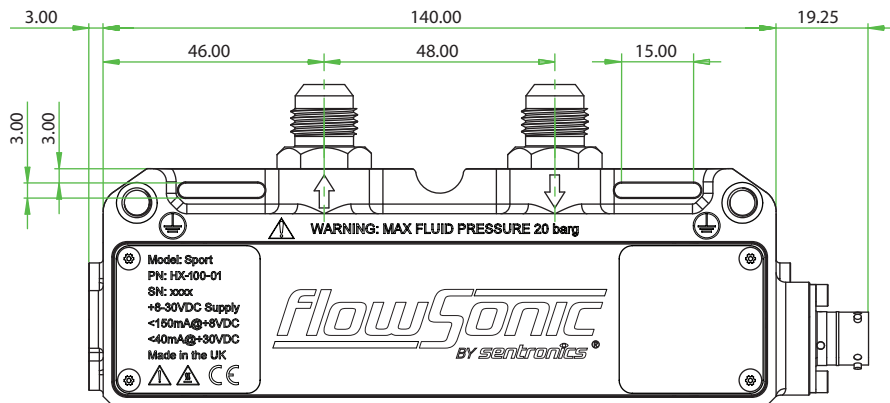

Complete general assembly drawing and CAD data available for download at www.sentronics.com

Pin Out Functions

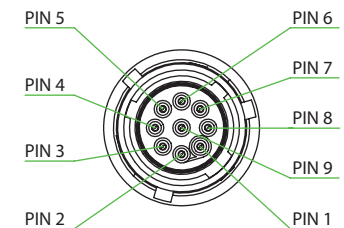

Pin 1	Supply +
Pin 2 / 3	CAN High 1 (CANH1) / CAN Low 1 (CANL1)
Pin 4 / 5	N/C
Pin 6 / 7	Comms A / Comms B
Pin 8	CAN Select
Pin 9	Ground (GND)

Model References

Model	Colour	Part Number	Description
Sport	●	HX-100-01	FIA F1® Team Meter
FIA	●	HN-100-01	FIA F1® Encrypted Reference Meter
GT	●	GT-100-01	General Motorsport Meter (used in IMSA® and FIA WEC®)

Measurement Performance

Flow Measurement

Measurement rate	2.2 kHz
Repeatability	± 0.05% of reading
Uncertainty*	± 0.25% of reading
Operating flow range	± 8000 ml/min (±480 LPH)
Calibrated measurement range	500-4000 ml/min (30-240 LPH)
Pressure drop @ 25°C	5kPa @ 2000ml/min, 15kPa @ 4000ml/min (WEC)

Temperature measurement 2 x 1000 ohm RTD (1/3 DIN standard)

* Calculated according to ISO/TR using root-sum square method yielding 95% confidence

Flow Outputs and Functions

Calibrated volumetric flow rate (ml/min)

Calibrated cumulative volumetric flow rate (ml)

Calibrated mass flow rate (g/min)

Calibrated cumulative mass flow (g)

Max/min logging

Elapsed time counter (power on, ETI)

Run time (flow time, RTI)

Speed of sound (m/s)

Diagnostics via CAN

Data Security and Encryption

Data encryption	●
Measurement anti-aliasing	●
Firmware security check-sums	● ● ●

Mechanical

Dry weight	330 g
Fuel capacity	15 ml
O-ring seal elastomer	FPM fluorocarbon
Wetted materials	FPM, anodised aluminium alloy, stainless steel
Fluid operating pressure	50 kPa to 2000 kPa, 8000 kPa maximum burst
Fuel line connectors	-6AN fittings 9/16-inch UNF thread

Electrical

Voltage	8V to 30V DC
Current	< 70mA @ +12V DC
Voltage protection	Over-voltage 45V DC, reverse polarity -45V DC
Deutsch sensor connector	● ● ASDD006-09PD-FI-952K ● ASDD006-09PA-FI-952K
Deutsch mating connector	● ● ASDD606-09SD-FI-952K ● ASDD606-09PA-FI-952K

CAN Communications

Design standard	ISO 11898-2 (high-speed applications)
Message format	2.0A (11-bit identifier)
Baud rate	1 Mbit/sec
CAN termination resistor	No
Configuration interface	3.3V serial interface

Fuel Compatibility

Pump petrol or diesel	F1® petrol blends
Methanol/petrol blends	WEC standard bioethanol/ETBE blend
Ethanol/petrol blends	IMSA standard E20C
Neat butanol, methanol, or ethanol	IMSA standard E10
Sustainable biofuel	

Environmental

Storage temperature	-40°C to 85°C
External pressure rating	300 kPa